

REV	ECN NO.	APP.	DATE
A	NEW DESIGN		

SPECIFICATION

- * Current Rating: 5 A
- * Withstanding Voltage: 1000 VAC (1 min.)
- * Insulation Resistance: 1000 Megohms MIN.
- * Contact Resistance: 30 Milliohms MAX.
- * Operating Temperature: -40°C to +85°C

ORDER INFORMATION

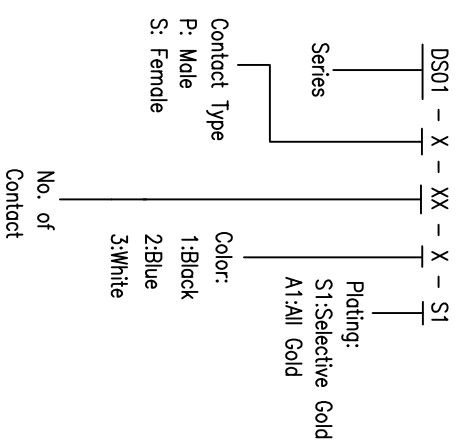

- * MATERIAL: Contact: Brass , Selective Gold or All Gold
- * Insulator: PBT & 30% G. F.
- * Shell: Steel , Tin Plated

PART NO.	A	B	C	D	E
DS01-X-09-S1	16.92	24.99	30.81	19.28	16.33
DS01-X-15-S1	25.25	33.32	39.14	27.51	24.66
DS01-X-25-S1	38.96	47.04	53.04	41.30	38.38
DS01-X-37-S1	55.42	63.50	69.32	57.71	54.84
DS01-X-50-S1	52.86	61.11	66.90	55.30	52.34

MALE

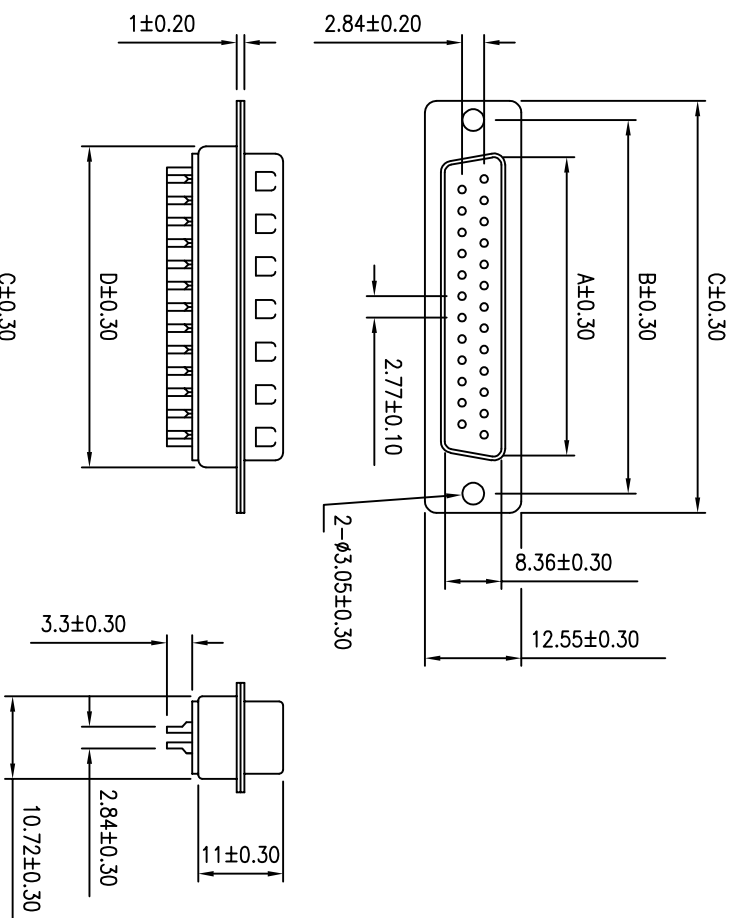

FEMALE

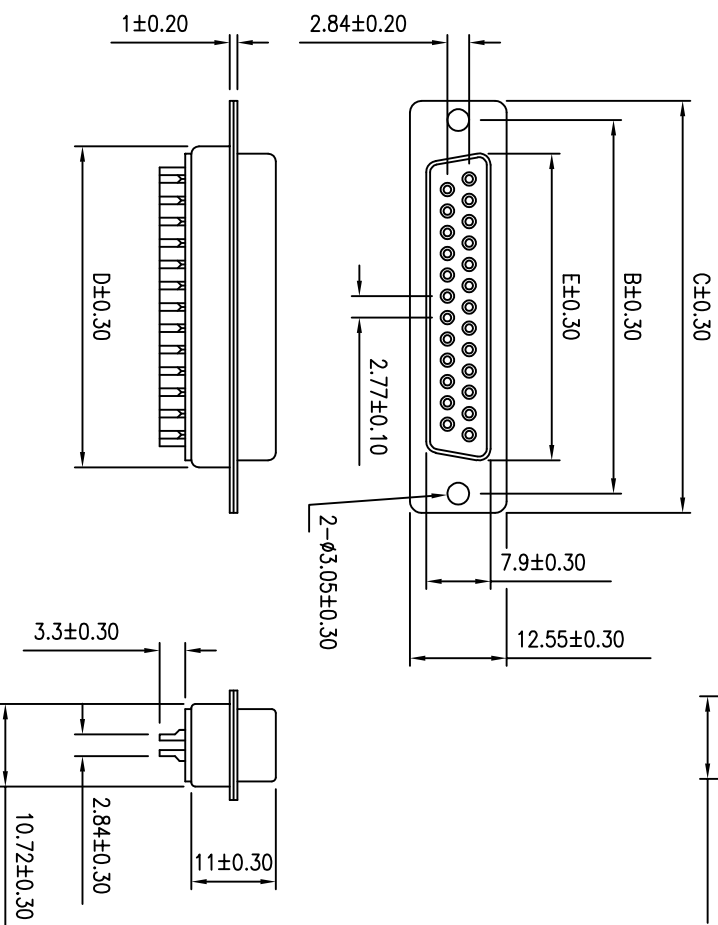

SHINHWHA TECH CO., LTD

0.0±	SCALE:	TITLE:	PART NO:
0.00±	UNIT: MM	D-SUB CONNECTOR	
0.000±		Solder Type	APP BY:
		MATL: PBT + 30% G.F.	CHK BY:
		DWG. NO. DS01	DR BY: